

Narrow fabric weaving machine

MULTICOLOR MVC2.8

for labels and trimmings
with woven, soft selvages



MVC2.8

Jacquard machines for multicolored labels with woven selvages

The Müller company's experience, constant technological innovations, and a solid basis of testing and inspection in the weaving shed have resulted in the development of this superb weaving machine, which justifiably enjoys a world-class reputation.

High demands in terms of productivity and quality require outstanding technical perfection and extremely high component reliability, without sacrificing versatility or increasing maintenance requirements. The machine's overall innovative aspects guarantee first-class processing of yarn for superior labels which meet the market's ever more demanding requirements.

The MVC2.8 is a further development of MVC2 including VARIPIC and VARISPEED (frequency controlled systems for the monitoring of weft density and machine speed). Furthermore the mechanical section was redesigned making the machine even more reliable and sturdy.

Fields of application and properties of labels and trimmings

A high level of flexibility in terms of application and universal fabric processing is guaranteed by the machine's engineering properties.

Depending on individual requirements, high-quality varicolored taffeta, satin or semi-satin labels can be produced from synthetic or natural yarns.

The weft threads provide the colors, the needle control producing a double pick. Depending on the number of weaving heads in the installation, between 4 and 8 colors may be used.

The ribbon selvages are interlaced by means of a special needle, resulting in markedly higher processing quality, reliability and comfort.

MVC installations are an ideal product for manufacturing labels and trimmings with complex patterns and high resolution.

Pattern production is performed by the electronically controlled Jacquard machine providing synchronized control of the selection of the weft and warp threads. The MVC's mechanical design makes it possible to switch from one article to the next without any downtime, assuming the same yarn colors and label widths. An additional requirement is the loading of the new program while the machine is still working on the previous article. As a result, the machine can also produce short runs or samples.



MVC2.8



Weft and warp feed



Weft feed and compensation

Build and technical properties

The use of high-value materials and the simplicity of the machine's basic movements guarantee a high level of long-term reliability, requiring relatively little maintenance of the installation.

Technologically high-calibre components are produced entirely within the Müller Group, with the utmost care and a first-class level of know-how. Our goal is to offer the customer a product of the highest possible quality:

- Patented multicolor weft insertion system (8 colors maximum)
- Weft transport with self-adjustment and tension compensation to guarantee even fabric width
- Machine speed set by the pattern program (setting by user surface possible)
- Slow motion with separate motor as standard
- Meets safety standards under CE directives
- Jacquard machine of SPE series, controlled by microprocessor
- Microprocessor UNI-control with USB-interface (Option: integrated floppy disk drive)
- MÜDATA®4 dialogue system integrated in control system
- Pattern creation with MÜCAD
- Warp from warp beams with elastic compensation, compensating roller system or DIGIKAST control system
- Selvedge threads and reps on separate warp bobbins
- Warp density can be increased by adding monofil threads, making interlacing points invisible and producing a homogenous sparkling effect
- VARISPEED and VARIPIC for the optimal monitoring of machine speed and weft density in accordance with label quality requirements

Thermosetting – Coiling

The MVC2.8 weaving machine possesses a number of perfectly integrated functions for post-weaving processing:

- In thermosetting, the tautened tape is flattened by means of a heated transport roller or a heated rail which automatically lifts up when the machine stops.
- Coiling is the last function performed by the MVC weaving machine, preparing the tape for subsequent processing.



Detail of harness, weft control, weaving heads

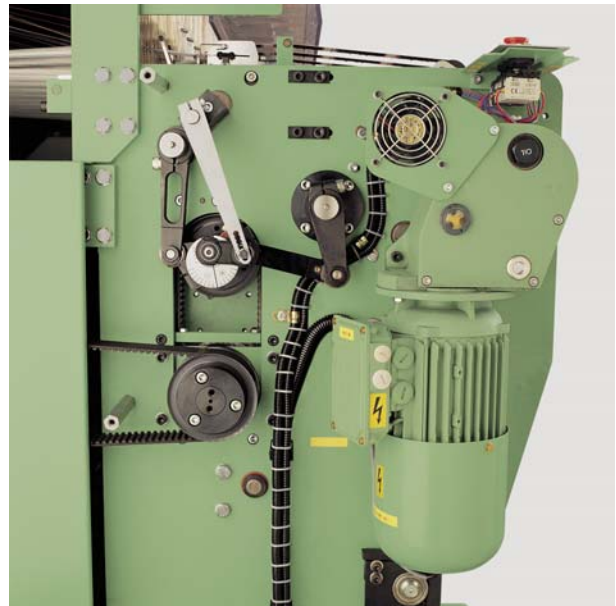

Automatic pick density regulator



Electronic warp let-off (DIGIKAST)

MVC2.8

Technical data – MVC2.8

Number of spaces		20	15	14	11	9	9
Nominal reed width in mm		24	30	36	50	57	66
min ⁻¹ mechanical speed		1400	1400	1400	1400	1400	1400
Max. beam Ø in mm	with compensating roller	700	700	700	700	700	700
	with DIGIKAST	800	800	800	800	800	800
No. of weft colors	standard	4	4	4	4	4	4
	optional	5	5	6	8	8	8

Note: For each design, the pick density for ground wefts per cm can vary between a minimum of 10 and a maximum of 80.

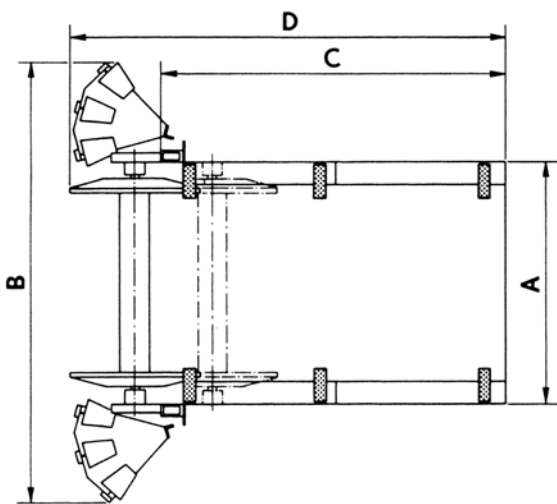

Weight and dimensions

	SPE 192	SPE 768
MVC2.8	2260 kg	2380 kg
Maximum machine height	2960 mm	3120 mm
Minimum room height	3210 mm	3300 mm

Space requirements

A	B	C	D
1350	2400	1900	2500

Copyright © 2001 by Jakob Müller AG Frick
5070 Frick Switzerland

Printed in Switzerland. All rights reserved.

No part of this publication may be reproduced by any means, nor translated, nor transmitted into a machine language without the written permission of the publisher.

This leaflet contains photos and technical data for information only, without contractual engagement.

**Fascination of Ribbons and Narrow Fabrics
Innovation in Machinery**

Rep.:



Jakob Müller AG Frick
5070 Frick Switzerland
Tel +41 62 8655 111
Fax +41 62 8655 777
www.mueller-frick.com

